

A meta-model for leveraging the ISA-88/95/106 standards

Jean Vieille

SyntropicFactory, Control Chain Group, Interaxys

j.vieille@syntropicfactory.com

Abstract. Considered together the ISA-88, 95 and 106 standards can be intimidating and confusing due to their large, overlapping scope, their different level of specialization and viewpoint. However their shared history, expert community, and domain of interest makes them conceptually consistent. This article proposes three simple but still expressive models to address the intended use cases of these standards. They can be specialized in any of the models in these standards providing a robust basis for an object oriented implementation. They can be used independently of these standards to develop industry / enterprise specific interoperability and functional design languages.

1. Introduction

The story began in 1990 with the ISA-88 « Batch control » standard that addresses modular automation for flexible batch processes. It was followed by the ISA-95 « Enterprise – control systems integration » standard that deals with manufacturing operations management (MOPM, MES) and interoperability. The latest ISA-106 “Procedural Automation for Continuous Process Operations” standard tackles procedural control for continuous processes. These standards provide good engineering practices for improving control design for industrial facilities. ISA-88 and ISA-95 are respectively published as international standards IEC61512 and ISO/IEC62264.

These standards share genetic concepts due to their consanguinity: many experts have contributed in the three standardization committees, which originated in ISA88.

Though their viewpoint, terminology and abstraction level sensibly differ, the way they handle structural and behavioural aspects is relatively consistent, allowing a quite straightforward retro engineering of their implied meta-model.

The interest of extracting a common meta-model of these standards is two-fold:

- It allows understanding the respective scope of each standard and their overlap.
- It makes easier to consider interoperability in the broader architectural approach of enterprise transformation

Despite its technical and specialized content, this article may be of interest even for people who are not fluent in the discussed standards, but who could appreciate that the thousand pages of these standards can be summarized into 3 simple generic models.

This short article does not develop extensively the derivation of the proposed meta-model into specific objects in the quoted standards. However, this meta-model has been successfully experimented both in the context of leveraging the standards within a small company that could not afford large consulting rates for implementing a compliant approach for interoperability and for developing an open, “lean B2MML” XML schema definition capable of handling any standard objects as well as company specific concepts.

2. Short overview of the discussed standards

ISA-88: functional design for control

Le ISA-88 standard « Batch Control » defines concepts and terminology for the design of automation of flexible batch facilities. It features the following aspects:

Modular automation design.

The standard enforces modular design and encourages object design by improving the potential of reuse of automation objects. This leads to reduced engineering effort, better knowledge management and more robust and evolvable applications

Industrial system flexibility.

Control is an integrated part of the facility that aims both at driving and at constraining the number of its possible states. When the number of products or services the facility has to deliver increases, the number of permitted states increases: control becomes more involved, hence potentially more difficult to implement. Flexibility expresses the ability of the facility to handle effectively the required behavior for each expected outcome under variable internal or external conditions. Control is for example challenged for delivering different products using different equipment, or the same product using different equipment which is a root requirement addressed by ISA-88.

Interoperability and Information.

ISA-88 provides a language (models and terminology, grammar and vocabulary) that may be used to support interactions between process engineers, operators, software vendors and system integrators. Data structures help for exchanging information between applications and for contextualizing it in production databases.

Description and Industrialization of manufacturing processes.

ISA-88 proposes to formalize (1) the product making knowledge in terms of physico-chemical transformations required to obtain a product with specified characteristics, (2) the operations sequencing for making the product in a given facility, and (3) a way to transform the neutral requirements (1) into executable operating procedures (2)

Applications.

ISA-88 is first a reference for the functional design of automation applications. Dedicated to flexible batch processes, it applies also to other manufacturing strategies that are considered less constraining, problematic for control engineers.

ISA-88 keeps distant from technology and does not fundamentally require specific features of DCS, PLC or SCADA/MES applications. However, It software vendors propose many ISA-88 labelled solutions: design tools, batch managers, data historians, and automation objects libraries.

ISA-95: MOM/MES and Interoperability

The ISA-95 standard defines data models for exchanging information between manufacturing related applications (ERP, MES, SCADA, LIMS, MMS, WMS...) as well as an activity framework for gathering requirements, designing functions, urbanizing applications for supporting manufacturing operations.

Industrial system operations management.

The ISA-95 standard discusses extensively the information supports to operations of industrial systems.

It is the de facto reference for managing the lifecycle of MES (Manufacturing execution systems) / MOM (Manufacturing Operations Management) domain functionalities (requirement, design urbanization, operations). It establishes a multi-dimensional map for managing related documentation and IT assets.

Interoperability.

ISA-95 define data structures for exchanging information between concerned applications. The UML models are implemented as XML schemas in B2MML.

Applications.

Opposite to ISA-88, ISA-95 seeks neutrality toward manufacturing typology. It is used as a functional design guide for information support to industrial systems and for the design standard for interfaces between software applications.

Software vendors have sometime used the data models to design their application persistence layer.

ISA-106: Procedural Automation for Continuous Process Operations

Launched in 2010, the ISA106 aims at promoting automated procedures in continuous processes. These processes were mainly designed for mass production, but are more and more required to be agile and optimized in terms of operations. The recent emphasis to safety, throughput and quality led to this effort to best design the automated starting, shutdown and exception handling of these facilities. The first technical report proposes models and terminology partially inspired from ISA-88 and ISA-95 to handle procedural design from requirement gathering to implementation.

3. Upper meta-model

The conceptualization of these standards builds on an upper level ontology that combines elementary concepts within the space-time continuum broken down to allow our World perception

The spatial view seeks to represent the observed system according to its shapes, non-time related characteristics. It is static, meaning that the representation from the observation at a given point in time is complete, or will not improve by a longer observation, supposing that all relevant information is captured instantaneously. This view can - will - evolve with time due to the continuous entropic (conflicts, “wear and tears”, market lagging) and negentropic (engineering, organization) transformation of the system and to its internal activities, ongoing interactions. However, this view does not address the “movement”: it is a picture, not a movie.

The temporal view represents the behaviour of the system, its functioning: process execution, event and subsequent activities that realize the system objectives.

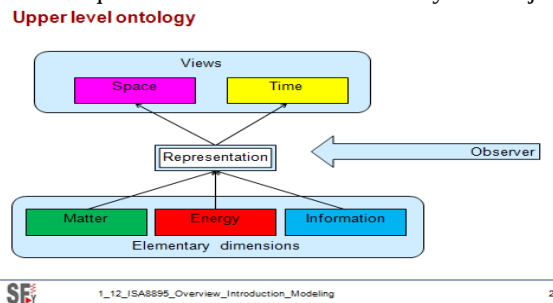

Fig. . Upper meta-model

From a transversal perspective, the system representation builds from a primary classification of the concepts involved in the existence and activity of the system: matter, energy and information. This is yet another human way of breaking down a fundamental continuum in order to facilitate observation, understanding.

These abstract concepts are the building blocks for the representations in the spatial and temporal views. Their meaning in the context of industrial systems as presented in the ISA-88/95 and 106 standards can be easily reified:

Matter

- The input/outputs of the system as material, parts and products that are bought, stored, elaborated, transformed, mixed, assembled, wasted, sold
- The components of the system as equipment that are installed, used, maintained.

Energy

- The input/outputs of the system as energy bought, stored, consumed, produced, wasted : fluids in closed circuits, electricity, combustibles
- Workforce involved in the system operation

Information

- Knowledge accrued in the system: product and process know-how
- Available documentation, used and created for or by the system operation,
- Organisation,
- Money available, spend, earned for and by the system operation, financial aspects.

The meta-model is now complete. The right rectangle is the spatial view (the system as it is observed in a specific point in time (the potentiality of the system)); the left pyramid is the time view (the kinetics of the system in action).

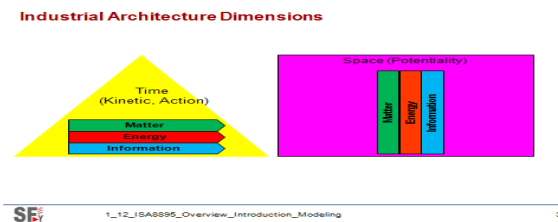

Fig. . Meta model for the study of ISA-88/95/106 standards

In the spatial view, elementary concepts – simple rectangles are considered under their potentiality, regardless their involvement in operations.

In the time view, the pyramid represent the decisional / behavioural hierarchy of the system in operation. The elementary concepts are arrowed: they are involved / allocated to participated in the system activity (kinetics)

Space-time relationship.

The time and spatial view split is convenient to grasp the complexity of the industrial system. In reality, they are tightly coupled because the living system keep evolving with time. Unless the factory is stopped, under nitrogen conservation, the spatial view is never up-to-date, it is only a representation snapshot if its state at a specific point in time.

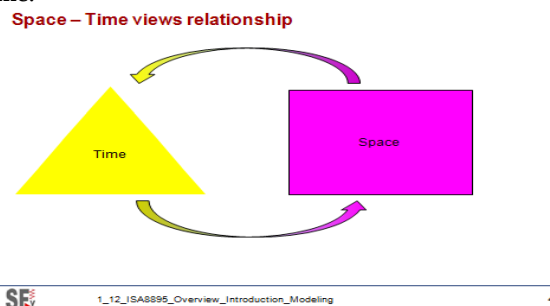

Fig. . Time-space coupling

In practice, the spatial view will describe the operating situations of the system in action, identifying and describing the Processes that are part of the spatial view as a knowledge asset, while the time view will consider the actual operation making use of this knowledge.

4. Application to ISA standards

Applying this upper level meta-model to ISA-88, ISA-95 and ISA-106 consists in specializing its generic concepts into each of these standards' equivalent concepts. This specialization takes into account the application domain and terminology of the target standards. This is a "reification process" that derives abstract concepts into more real, tangible ones.

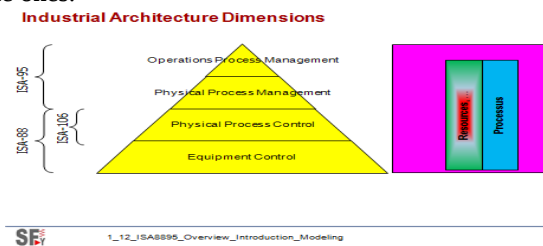

Fig. . Meta-model reification

Elementary dimensions

The notions of matter and energy are not always clearly segregated. An electrical consumption is with no much doubt considered as « pure energy”, but oil holds obviously both dimensions. In reality, matter and energy, which are physically so distinct, are always combined in tangible streams involving the combination of matter and energy driven by machines and people.

To escape this ambiguity, the meta-model, as ISA-95 will not make a distinction between both. Actually, from the enterprise viewpoint, matter and energy are of the same nature: they are both inputs and outputs of their main value chain process, not something that is part of them as a constituency asset. This does not preclude specific, different management approaches to energy and matter streams.

ISA-95 defines the notion of *Resource* that takes matter and energy as one of them along with people (person) and machines (role based equipment and physical asset) that is understandable in the context of ISA-88 and ISA-106.

The de-correlated resource description always appears in the context of an activity: in-formation gives form to something. In this original sense, information is at the hearth of the transformation processes seeking a useful outcome: combining matter and energy carelessly, without any *knowledge* will move the matter to an equal entropy state at best while an organized, knowledge based process will produce a more sophisticated process than the original combination of raw material.

This knowledge – information- is potential as long as it stays in peoples and computers memories, kinetics when it is in action. In the latter case, Information sticks to the action it make productive by consuming energy unless it is useless or entropic (can it be negative information?). Said another way: during an industrial process transformation, the entropy of the blend of incorporated material decreases by consuming energy, countering the so-called fated entropy increase of the universe.

For this reason, the information dimension appears under the more practical, less open ended term Process applicable (with some possible confusing broadened definition) to many elements of resources mobilization quoted with numerous terms in the standards. For example, ISA-95 part 2 *Product definition*, *Product segment*, *Process segment*, *Production request* ... correspond to Processes in the meta model.

Spatial view

ISA standards focus on operational aspects of industrial systems, not on their transformation. Resources are summarily addressed in the context of their contribution to operations. Processes in ISA standards mainly address operational activities to fulfil short-term market demand. ISA-88 par 3 goes further by tackling product design to manufacturing. The spatial view is then limited to the description of basis physical and informational entities involved in manufacturing.

Time view

From the studied standards, the time representation of the operating system can be represented as a decisional, functional, behavioural hierarchy of four levels: *Operations Process Management* for operational processes, *Physical Process Management* and *Physical Process Control* for management and control of physical equipment.

5. Spatial view - Resource

Resource meta-model

Only ISA-95 proposes a resource model. Other ISA standards address partial aspects that are all more extensively defined in ISA-95.

ISA-TR106-01 does not offer a formal model; it only defines an alternate terminology for ISA-88 concepts.

The resource meta-model presented in the following figure includes the following sub-classes

- *Type* corresponds to the ISA-95 canonical model such as *Equipment*, *Material*, *Person and other specifics*
- *Role* is a functional classification that allows to allocate resource quantitatively and qualitatively without naming explicitly the corresponding

resources. It corresponds to ISA-95 *class* concept in equipment and personnel resource, or material definition in material resource.

- Category is a complementary classification less constraining than roles to further adapt resource definition to specific businesses. It corresponds to ISA-95 Class concept in the material model.
- *Context* defines the situation the resource is involved :
 - o *Master* for out of any context definition
 - o *Usage* for qualitative involvement of resources in Definition and Execution of the knowledge meta-model
 - o *Capability* for quantitative instances of resources in the capability model

- *Entity* is the tangible, identified resource

To this object are associated:

- *Properties* that characterize the object
- *Test specifications* associated to properties
- Test results of the time-stamped triplet *Entity/Property/Test specification*

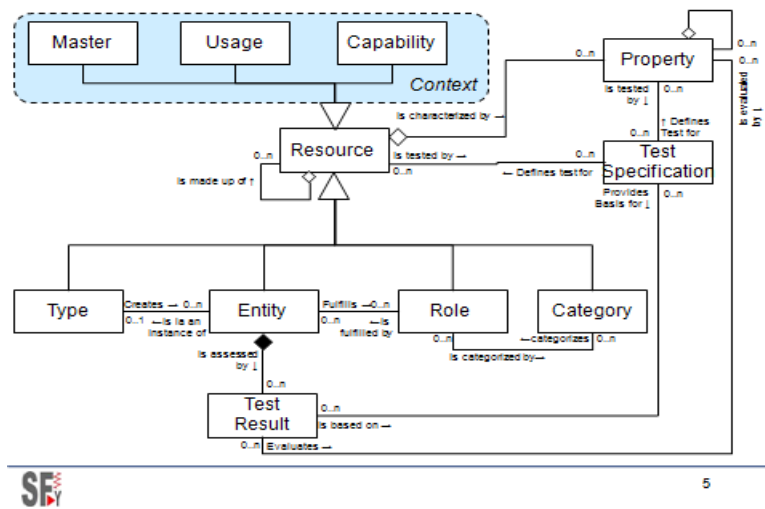

Fig. . Resource meta-model

The following figure shows an example of a type of resource not defined by ISA-95, though very usual in industry: the packing unit that combines a certain quantity of product and a packaging item. The abstract, recursive meta-model allows a straightforward definition that still conforms to ISA-95 inner spirit. This heterogeneous combination of a “container” and a “material” is not possible using the native ISA-95 model.

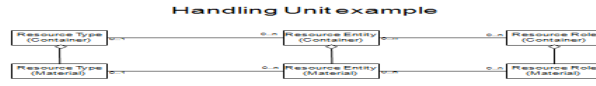

Fig. . Example of extending the ISA-95 resource concept

Resource master meta-model mapping

The resource meta-model is specialized in 4 subclasses in the studied standards. Only ISA-95 handles resources in a detailed manner (not in Part 3 though). Other standards treat resources superficially.

Meta-model	ISA-95.02	ISA-95.04	ISA-88.01/2/4	ISA88.03	ISA-TR106.01
Resource Master	Personne				
>Personnel	1				
Resource Master	Role based		Equipment entity, Physical model	Equipment requirement	Physical model
>Role based equipment	equipment, Physical asset,				
>Physical asset	physical model,				
>Equipment entity					
Resource Master	Material		Formula	Material definition	
>Material					
Resource Master		Resource relationship network			
>reference					

Resource Master > Personnel

Only ISA-95 part 2 defines the *Personnel* resource. It is represented in the following UML class diagram.

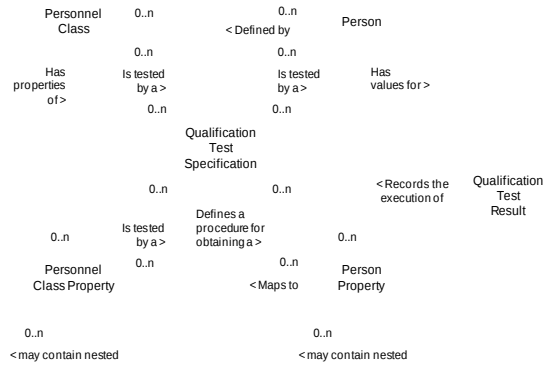

Fig . ISA-95 Personnel model

The meta-model mapping is defined in the following table:

Resource model	meta-model	ISA-95 model	Personnel	Comments
Resource type		“Personnel”		This is the model itself. ISA-95 does not recognize explicitly the meta-concept of resource.
Type property		-		Not explicit in ISA-95
Resource entity		Person		Recursivity is not used/allowed in ISA-95
Entity property		Person property		
Resource Role		Personnel class		Recursivity is not used/allowed in ISA-95
Role property		Personnel class property		
Resource category		-		Not used
Category property		-		Not used
Test specification		Qualification specification	test	
Test result		Qualification test result		

Resource Master > Equipment

ISA-95 defines 2 similar models to represent equipment.

- the *role based equipment* model corresponds to the equipment in action in the facility;
- the *physical asset* model corresponds to the static asset from its financial or maintenance viewpoint.

Any actual equipment can be represented in both models within different hierarchies, providing different attributes that are relevant in context. This association is handled by a specific data object.

They are represented in the following UML class diagrams.

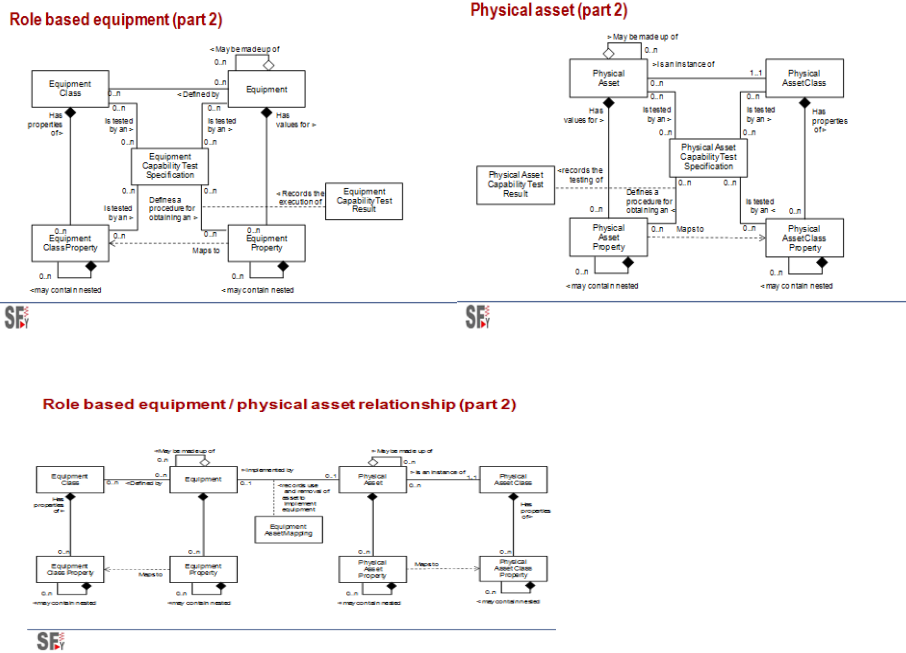

Fig. . Table . Figure ISA-95 Equipment models

The meta-model mapping is defined in the following table:

Resource meta-model	ISA-95 Role based equipment model	ISA-95 Physical asset model	Comments
Resource type	“Role based equipment”	“Physical asset”	This is the model itself. ISA-95 does not recognize explicitly the meta-concept of resource.
Type property	-	-	Not explicit in ISA-95
Resource entity	Equipment	Physical asset	
Entity property	Equipment property	Physical asset property	
Resource Role	Equipment class	Physical asset	Recursivity is

		class	not used/allowed in ISA-95
Role property	Equipment class property	Physical asset class property	
Resource category	-	-	Not used
Category property	-	-	Not used
Test specification	Equipment capability test specification	Physical asset capability test specification	
Test result	Equipment capability test result	Physical asset capability test result	
N/A	Equipment asset mapping		Can be handled by the recursivity that allows mixing different types of resources (the physical asset can be embedded in the role based equipment)

Resource Master > Material

The material model is more complete, involving material definition, class as category, lots and sublots. It is represented in the following UML class diagram.

Material model (part 2)

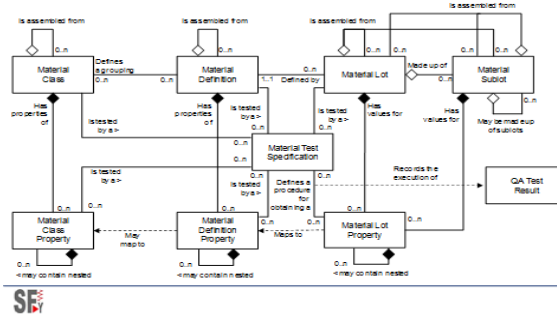

Fig. . ISA-95 Material model

The meta-model mapping is defined in the following table:

Resource model	meta-	ISA-95 Material model	Comments
Resource type		“Material”	This is the model itself. ISA-95 does not recognize explicitly the meta-concept of resource.
Type property		-	Not explicit in ISA-95
Resource entity		Material lot / subplot	Sublots is useless as the lot is recursive (kept for compatibility with old ISA-95 versions)
Entity property		Material lot property	
Resource Role		Material definition	Recursivity is not used/allowed in ISA-95
Role property		Material definition property	
Resource category		Material class	
Category property		Material class property	
Test specification		Material test specification	
Test result		QA test result	

6. Spatial view - Process

Process meta-model

A *Process* represents one aspect of knowledge as a structured course of actions to achieve an objective. The 3 standards address functional knowledge of industrial facilities with significant overlap.

ISA-95 defines segment, definition, capability, schedule and performance; ISA-88 defines several types of recipe; ISA-106 defines procedure. All these specific concepts collapse into 3 contextualized concepts, sub-classes:

- *Master* is used for the definition of processes
- *Execution* is used for activity programs
- *Capability* is used for the time projection of means – *resources* and *master processes*

The process itself includes:

- *Resource instances* – the qualified/quantified, allocable/allocated resources for its accomplishment
- *Parameters* – the data inputs for influencing its implementation
- *Data* – the data outputs to report its execution

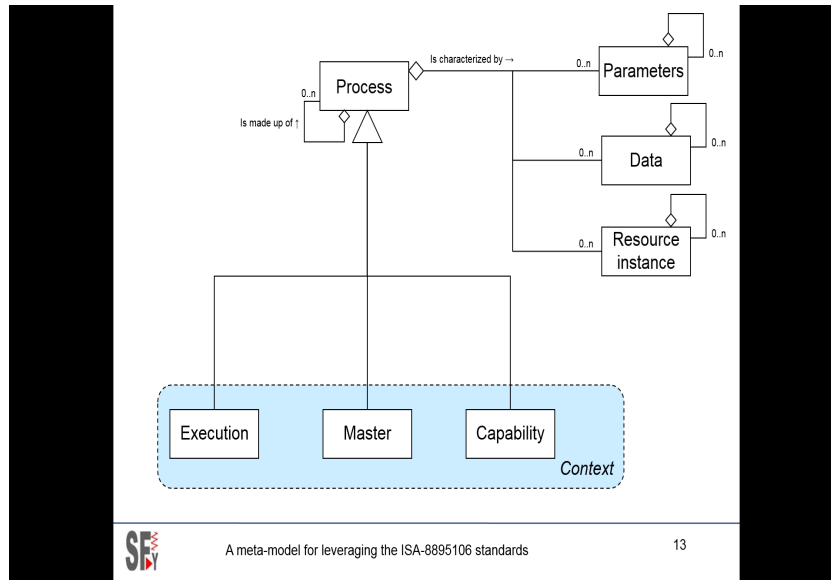

Fig. . Process Meta-model

Process meta-model mapping

The 3 process subclasses subclasses are handled by ISA-88 and ISA-95. ISA-106 only defines the Master process subclass.

All standards look at the processes from 2 viewpoints: the product view that describes the requirements for making the product and the equipment view that describes the ability of the facility to fulfil these requirements. The meta-model does not make this distinction.

in the studied standards. Only ISA-95 handles resources in a detailed manner. Other standards treat resources superficially.

The meta-model mapping is defined in the following table:

Process Meta- model	ISA- 95.02	ISA- 95.04	I SA- 95.0 3	ISA- 88.01/2/4	ISA88 .03	ISA- TR106.01
Process >master (ability)	Proces s segment	Work Master Workfl ow specificati on		Equip ment Procedur al Element		Implemen tation modules
Process >master	Operat ions	Work definition		Master , control	Equip ment	Procedure Requirement

(requirement)	definition Product segment	Work directive	Recipe Process model General, site recipe Recipe Procedural element Batch schedule	independent recipe Process element	s Procedure Implementation
Process >execution	Operations schedule	Work schedule			
Process >execution	Operations performance	Work performance	Production Information Batch record		
Process >capability	Operations capability	Work capability			

Process >master

This model describes the process and activities as potentially applicable know-how as a catalog of capabilities, services, products. It applies to two viewpoints:

- The capability as the processing know-how embedded in the facility that can be applied in different circumstances and products;
- The requirements as the processing know-how specification to make a product regardless the facility that implements it.

The three standards are explicit on this distinction, though from a different perspective. ISA-95.02 defines *process segment* vs *operations segments*; ISA-88 defines *Recipe* and *Equipment*; ISA-106 defines *Requirements* and *Implementation*

They induce a difference between the upper level object (i.e. *Definition, Recipe, Procedure...*) and its breakdown (*Segment, Directive, Procedural element, Requirement, Module*). This may be confusing because they are semantically identical (a segment can be itself a definition from a more local perspective).

The meta-model demonstrates the possible simplification recognized de facto in ISA-95 part 4 that equates *Work master, Work directive* and *Work definition* as common, recursive processing descriptions. Actually, an activity in a process is

always itself a process: the recursivity stops to the level of detail addressed by the model.

ISA-95 Workflow specification adds a structured, machine interpretable description of the process.

Process >execution

This model describes the work to be done, under execution or executed. It adds time related planning information to process master. Only ISA-88.01/02 and ISA-95.02/4 address this aspect. ISA-95 adds the suffix *Schedule* or *Performance* for planned or realized work though the models are basically identical. ISA-88 part 2 also defines the *schedule* notion while ISA-88 part 4 consolidates execution information into a comprehensive structure that incorporates ISA-95 Operations performance and numerous resource or process related objects.

Process >capability

Capability is only defined by ISA-95. It is actually a query model for various criteria: time, localization, availability... Capability applies to resources directly or through processes.

7. Time view

Functional meta-model

The time view takes the operational context of the industrial facility to define or observe its behavior.

Unlike spatial view, that characterizes the ability or the status of the system at a given point in time, the time view addresses the functioning, the unfolding of successive states of the system in time. This links to the execution of processes addressed in the spatial view, but from their trigger, monitoring, analysis viewpoint.

The time dimensions are not formally addressed in any of these standards. For example, an operations schedule is part of the spatial view because it is a piece of knowledge that can be potentially actioned. The time view addresses the building of this schedule, the triggering of the orders, the monitoring of the subsequent manufacturing, making the factory actually moving.

The meta-model is a simple structured classification scheme of the standards' functional concepts. It defines a recursive *Function* meta-object to describe all useful level from macro processes to elementary tasks in all operating contexts.

- Functional representation context is supported by the element lifecycle that guides description detail requirement, from identification of the business needs to the operations documentation
- Temporal dimension links the function to the decisional hierarchy as suggested by the ISA standards

- o *Operations Process Management* :
This dimension addresses operational business processes such as demand management, work order monitoring, performance management. It is decoupled from physico-chemical-biological transformations and operational knowledge of industrial activities.
 - o *Physical Process Management* :
This dimension addresses the management of physical processes such as product quality and performance criteria, facility capability and performance. It takes systemically the physical process as a black box, observing I/Os, sending low variety orders, measuring operational and economical results.
 - o *Physical Process Control*
This dimension addresses the execution of physical processes to realize the ordered products or services such as routings, recipes, operating procedures. It is at the heart of the enterprise specific know-how.
 - o *Equipment control*
This dimension addresses information support to equipment to make them capable of offering the required process services for executing physical processes, including basic automation and control. It is at the heart of the engineering knowledge of industrial facilities.
- Granularity corresponds to the different concepts in the functional hierarchy for every dimension, every standard, such as *Procedure, Unit procedure ; Operation, Phase* in ISA-88; *Operations definition, Work definition, Operations segment, Work segment, Activity, Task...* in ISA-95
 - Operation category is introduced by Isa-95 for classifying operational functions (*Production, Maintenance, Quality, Inventory*)

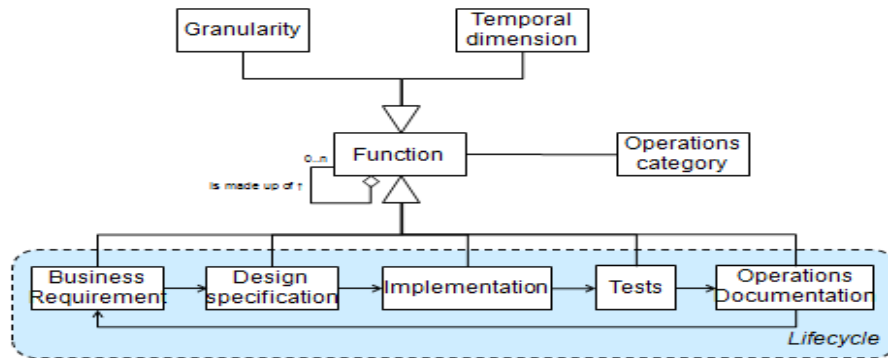

Fig. . Function meta-model

Function meta-model mapping

The meta-model mapping is defined in the following table:

Méta-modèle	ISA-95.03	ISA-88.01/2/4	ISA88.03	ISA-TR106.01
Equipment control		Basic control		Implementation on modules
		Procedural control Coordination control		Procedure Implementation
Physical process control		Process control Unit supervision		Procedure Implementation
Physical process management	Definition management	Recipe management		Procedure Requirement
			Transformation of equipment	

			independent recipes to master recipes
Operations process management	Resource Management Detailed scheduling Dispatching Execution management Tracking Data collection Performance analysis	Production planning and scheduling Process cell management Production information management	

8. Conclusion

The ISA standards presented in this article are well known and largely adopted in industry.

We could regret their seemingly lack of consistency and the considerable volume of this documentation due to the segmented, consensual mode of development without common guideline by independent committees over a long period.

It is unlikely that these standards will adopt an ontological design approach as presented here. They will keep evolving, enriching under the same spirit as long as they represent an interest for industrialists. Recent updates extended, clarified, and aligned their definitions. ISA-88 ended up validating heretic interpretations of its original concepts, ISA-95 added a 4th part that bring confusion more that addressing real problems.

This study shows that this huge documentation might collapse into few abstract concepts, highlighting and encouraging conceptual convergence that was not envisioned in the context of their development.

These standards have reached a certain maturity and have proved their value, while applications are still lagging behind their true potential:

- ISA-88 object oriented design, knowledge management based approach is still not applied. The vision merely goes beyond the project, with minimal know-how reuse from one application to another, even less at the enterprise and supra-enterprise levels. Its generalization beyond batch processes is hindered by its title and the committee reluctance – they preferred to create a new standard for continuous processes (ISA-106).

- The supply chain benefits of a certain attention: ISA-95 is often involved for integrating demand processes. However, the functional approach and application integration of the design chain respectively addressed by ISA-88 and ISA-95 are rarely used.
- The interest of an industrial information repository begins to be perceived (traceability, performance and process improvement). The ISA-88 part 4 is an invaluable resource that is definitely misplaced in this "batch" tagged standard. It should be moved to ISA-95 instead.

Industrialists will find in these standards conceptual elements and guidelines for an effective design addressing most of the functional aspects of industrial IT within all the control chain, from operational planning to equipment control, from product and facility design to launch in production.

They are not perfect nor comprehensive, but the appropriation of their underlying concepts revealed by this study shall help to build an enterprise wide framework within which standards can be adapted and expanded to cover actual business needs.